



## **KD-Relay Remote Display 4x20 Display**

# **User Manual**

KD-RDU-420  
Version 00.01  
(NE\_KD-RDU-420\_MAN\_00\_09\_FN01)

02 November 2009

NewElec Pretoria (Pty) Ltd  
Head Office: c/o 298 Soutter street & Maltzan street  
Pretoria West  
South-Africa  
0182

GPS: 25°45'12"S 28°09'46"E

[Http://www.newelec.co.za](http://www.newelec.co.za)

## Content

.....	
1. ABSTRACT .....	3
2. SPECIFICATIONS.....	4
2.1 Technical Specifications of RDU .....	4
2.4 Menu Structure with Unit Ranges of MMI .....	5
2.4.1 Main Menu (primary menu - 1st level) .....	5
2.4.2 Actual Values (2nd level) .....	5
2.4.3 Relay Settings (2nd level) .....	5
2.4.4 Faults – (2nd level).....	5
2.4.5 Events – (2nd level).....	6
2.4.6 RDU Settings (2nd level) .....	6
2.4.7 Relay Data Time - (2nd level) .....	6
2.4.8 Relay Info (2nd level).....	6
2.4.9 Settings (3rd level) .....	7
2.4.10 Input Pointers .....	8
3. DEFINITIONS AND TERMINOLOGY .....	9
4. FUNCTIONAL DESCRIPTION.....	10
5. OPERATING INSTRUCTIONS .....	11
5.1 Getting Started.....	11
5.1.1 Installing KD-RDU-420 .....	11
5.2 Navigating Through The Menus .....	11
5.3 Monitoring Actual Data.....	11
5.4 Change or Viewing Settings .....	11
5.4.1 Change in RDU memory slots .....	12
5.4.2 Copy RDU memory slot to RDU memory slot .....	12
5.4.3 Upload relay settings to RDU memory slot .....	12
5.4.4 Download MMI memory slot to relay.....	12
5.5 Retrieve and Uploading Event / Fault Records .....	12
5.6 Trouble Shooting (Frequently Asked Questions) .....	13
6. DIAGRAMS.....	14
6.1 Physical Layout of the RDU .....	14
6.2 Layout Of RDU Front Panel .....	15
6.3 Layout Of RDU Back Panel .....	16
6.4 Block Diagram of RDU Display Unit .....	17
6.5 Menu Layout .....	18
6.6 Mechanical Installation Drawing .....	19
6.7 Wiring Diagram.....	20
6.8 Mechanical Drawing .....	21
7. ACCESSORIES .....	22
7.1 RDU To Relay Communication Cable .....	22
7.2 NewElec RDU Dongle Key .....	22

## 1. ABSTRACT

The KD-RDU-420 (KD-Relay Remote Display Unit 4x20 Character Display) is a door mounted display unit, designed to function together with the KD or KE motor protection relays. It is advisable to read this manual in conjunction with KD or KE user manual.

The purpose of this unit is to provide a front-end facility (man machine interface) between the operator and the motor protection relay. It is capable to monitor and adjust the motor protection relay data (if a dongle key is plugged in). The relay data consists of settings, faults, events and actual data. Settings can be adjusted as a batch or individually. Communication between the motor protection relay and the display unit (RDU) is done with a communication cable (CAB0100). IrDA lens can be found on the front control panel of the display unit, which the KD-MMI-420-EP or KD to PC cable can use to communicate to the KE or KD relay without opening up the MCC door.

## 2. SPECIFICATIONS

### 2.1 Technical Specifications of RDU

General Data	Mounting Positions	<input checked="" type="checkbox"/> Door Mounted <input checked="" type="checkbox"/> 132 mm x 71 mm Cut Out
	Allowed Ambient Temperature	<input checked="" type="checkbox"/> Operation : 0 °C to +60 °C
	Humidity	<input checked="" type="checkbox"/> < 87%
RDU	Power Supply	<input checked="" type="checkbox"/> 110 to 220 Vac @ 50/60Hz
	Consumption	<input checked="" type="checkbox"/> 75 mA
	Communication Mediums	<input checked="" type="checkbox"/> IrDA <input checked="" type="checkbox"/> RS232
	Physical Dimensions	<input checked="" type="checkbox"/> 145.84mm X 86.00mm X 70.92mm
	Mass Of Unit	<input checked="" type="checkbox"/> 375 gram
IrDA	Communication Distance	<input checked="" type="checkbox"/> 1 Meter
	Board Rate	<input checked="" type="checkbox"/> 19200 bits per second
RS232	Communication Distance	<input checked="" type="checkbox"/> 25 Meters
	Board Rate	<input checked="" type="checkbox"/> 19200 bits per second
Display	Type	<input checked="" type="checkbox"/> 4 lines by 20 Characters. <input checked="" type="checkbox"/> Liquid Crystal Display (LCD).
	Character Size	<input checked="" type="checkbox"/> 5mm X 4 mm
Keyboard	Type	<input checked="" type="checkbox"/> Diafram
	Keys	<input checked="" type="checkbox"/> Up <input checked="" type="checkbox"/> Down <input checked="" type="checkbox"/> Left <input checked="" type="checkbox"/> Right <input checked="" type="checkbox"/> Down <input checked="" type="checkbox"/> Enter <input checked="" type="checkbox"/> Reset or Menu
Indication Lights	Type	<input checked="" type="checkbox"/> Light Emitting Diode (LED)
	LED Indications	<input checked="" type="checkbox"/> Relay Communication <input checked="" type="checkbox"/> In Service <input checked="" type="checkbox"/> Trip
CAB0101	Length	<input checked="" type="checkbox"/> 2 meters

## 2.4 Menu Structure with Unit Ranges of MMI

### 2.4.1 Main Menu (primary menu - 1<sup>st</sup> level)

- 1>Actual values
- 2>Relay settings
- 3>Faults
- 4>Events
- 5>RDU Settings
- 6>Relay Date Time (Real Time Clock)
- 7>Relay Info

### 2.4.2 Actual Values (2<sup>nd</sup> level)

- Load – Load current expressed in % (0 – 999%)
- TC level – Thermal capacity used expressed in % (0 – 100%)
- Vlev – Maximum Phase voltage (0 - 1200V), Vr – Red phase voltage (0 - 1200V)
- Vw – White phase voltage (0 – 1200V), Vb – Blue phase voltage (0 – 1200V)
- EL – Earth leakage (0 – 3000mA)
- Unbalance – Current unbalance (0 – 100%)
- Volt Sym – Voltage symmetry (0 – 50%)
- Power Factor – Power factor expressed as a % (0 – 100%)
- Iso. Lock – Isolation lockout expressed in k Ohm (0 – 200kOhm)
- Relay 1 – Relay 1 operation status (energized / de-energized)
- Relay 2 - Relay 2 operation status (energized / de-energized)

### 2.4.3 Relay Settings (2<sup>nd</sup> level)

- RDU Mem Slot
- Copy Slot → Slot
- DwnLd Slot → KX
- Upload KX → Slot

### 2.4.4 Faults – (2<sup>nd</sup> level)

Fault history retrieved from relay database

- View [Nr] – Fault number x of 60 on display
- Status – Actual fault (caused by real current and voltage) or sim. Fault caused during simulation of current, voltage, power factor and earth leakage current)
- Type – Trip condition (Any one of the trip flags which is applicable at the time of the trip)
- DT – Date and time stamp of fault record.

- Run hour – Motor running hours at the time of the trip expressed in hours.
- Current – Max current in % at the time the trip took place (0 – 999%).
- Voltage – Minimum phase voltage at the time of the trip (0 – 1200V)
- Contact R.T. - Contact release time or time to clear fault expressed in ms. (0 – 1000ms)

#### 2.4.5 Events – (2<sup>nd</sup> level)

Event history retrieved from relay database

- View [Nr] - Event number x of 2000 on display
- Status – Event type (alarm, trip or setting adjustment)
- DT – Date and time stamp of the event record.
- Alarm Flags – Alarm condition at the time of the recording of the event.
- Trip – Trip condition at the time of the event recording.
- Run hour – Motor running hours at the time of the recording of the event.
- Current – Maximum current at the time the event was recorded.
- Voltage – Minimum phase voltage at the time of the event recording.
- Contact R.T. - Contact release time or time to clear fault expressed in ms. (0 - 1000ms)

#### 2.4.6 RDU Settings (2<sup>nd</sup> level)

System settings only for the RDU (not applicable for the relay)

- Auto scroll – Auto scroll the actual values after 5 minutes of no key activity (Enabled / Disabled).
- Back light auto on – Backlight will be turned off after 5 minutes (Enabled / Disabled).
- Contrast – Contrast adjustment of the LCD images (0 - 100%).
- Brightness – Brightness adjustment of the LCD back light (0 – 100%).

#### 2.4.7 Relay Data Time - (2<sup>nd</sup> level)

- Date – Relay date adjustment of the real time clock of the relay.
- Time – Relay time adjustment of the real time clock of the relay.

#### 2.4.8 Relay Info (2<sup>nd</sup> level)

Statistical and user data to manage the drive:

- Start-up counter – Increment every when the motor starts up (0 - 65535).
- Trip counter – Increment every time when a trip occurs (0 – 65535).
- Running hours – Increment every hour the of motor operation (0 – 65535).
- Drive description – Description of drive (20 characters).
- Drive file ID – Unique file name associated with the drive.

## 2.4.9 Settings (3<sup>rd</sup> level)

- TC Class Select – Thermal Curve Class (5 – 40sec)
- Maximum Load Set – Motor full load setting (10% - 100%)
- Voltage Select – Supply line voltage level (110V, 400V, 525V or 1050V)
- V Sym Trip Level – Voltage symmetry trip level (50% - 100%).
- Unbal Trip Level – Current unbalance trip level (0% - 50%)
- Unbal Trip Delay – Current unbalance trip delay (1 – 10 sec)
- U/C Trip Level – Undercurrent trip level (10 – 99%)
- U/C Restart Delay – Undercurrent restart delay (Manual, 10s, ..., 1 h, 3h, 6h)
- U/C Trip Delay – Undercurrent trip delay (1 – 10 sec)
- EL Trip Level – Earth leakage trip level (0 – 3000 mA)
- EL Trip Delay – Earth leakage trip delay (100ms – 1sec, in steps of 50ms, IDT)
- EL Curve Select – Earth leakage curve select (Instantaneous Definite Time / Inverse Definite Minimum Time)
- Starts per hour – Starts per hour allowed (0 – 30);
- U/C Startup Delay – Undercurrent start-up delay, pump priming time (0 – 200s)
- Power Fact Level – Power factor trip level setting (0 – 100%)
- TC Reset Level – Thermal capacity reset level (10 – 100%, default = 70%)
- Consec Start Lim – Consecutive starts limit (1 – 3)
- Run Stall T Level – Run-stall Trip Level (110% - 300%)
- Run Stall H Time – Run-stall hold off time (1 – 200s)
- U/C Trip – Undercurrent trip (Enable / Disable)
- Under Volt Trip (Enable / Disable)
- Over volt Trip (Enable / Disable)
- Volt Synt Trip – Voltage symmetry trip (Enable / Disable)
- Fail Safe – (Enable / Disable)
- Auto TC Reset – (Enable / Disable)
- Unbalance Trip – Current unbalance trip (Enable / Disable)
- Phase Rot Trip – Voltage phase rotation trip (Enable / Disable)
- Short Circ Trip – Short circuit Trip (Enable / Disable)
- Single phase trip – (Enable / Disable)
- Running Stall T – Run-stall trip (Enable / Disable)
- Sel. U/C for Trip - Undercurrent / Power factor selected for trip (Enable / Disable)
- Earth leakage Trip – Earth Leakage Trip (Enable / Disable)
- Low Pass Filter – (Enable / Disable)
- Iso. Lockout T – Isolation lockout trip (Enable / Disable)
- Frequency Trip – Frequency monitoring (Enable / Disable)
- Auto TC Reset Cal – (Enable / Disable)
- Starts Per Hour – (Enable / Disable)
- Volt Phase Rev – (Enable / Disable)
- Vectorial Stall T – Vectorial stall trip (Enable / Disable)
- Table 1 Mask 0&1 – 000:X, 001:X (X=0/1)
- Table 1 Mask 2&3 – 010:X, 011:X (X=0/1)
- Table 1 Mask 4&5 – 100:X, 101:X (X=0/1)

- Table 1 Mask 6&7 – 110:X, 111:X (X=0/1)
- Table 1 Input A – (Input pointer – see 2.4.10)
- Table 1 Input B – (Input pointer – see 2.4.10)
- Table 1 Input C – (Input pointer – see 2.4.10)
- Table 2 Mask 0&1 – 000:X, 001:X (X=0/1)
- Table 2 Mask 2&3 – 010:X, 011:X (X=0/1)
- Table 2 Mask 4&5 – 100:X, 101:X (X=0/1)
- Table 2 Mask 6&7 – 110:X, 111:X (X=0/1)
- Table 2 Input A – (Input pointer – see 2.4.10)
- Table 2 Input B – (Input pointer – see 2.4.10)
- Table 2 Input C – (Input pointer – see 2.4.10)
- Table 3 Mask 0&1 – 000:X, 001:X (X=0/1)
- Table 3 Mask 2&3 – 010:X, 011:X (X=0/1)
- Table 3 Mask 4&5 – 100:X, 101:X (X=0/1)
- Table 3 Mask 6&7 – 110:X, 111:X (X=0/1)
- Table 3 Input A – (Input pointer – see 2.4.10)
- Table 3 Input B – (Input pointer – see 2.4.10)
- Table 3 Input C – (Input pointer – see 2.4.10)
- Timer A Time Out – (0 – 3000s)
- Timer A Start In – (Input pointer – see 2.4.10)
- Timer A Reset In – (Input pointer – see 2.4.10)
- Timer B Time Out – (0 – 3000s)
- Timer B Start In – (Input pointer – see 2.4.10)
- Timer B Reset In – (Input pointer – see 2.4.10)
- Start Motor – (hh:mm)
- Stop Motor – (hh:mm)
- Relay 2 Input Sig - (Input pointer – see 2.4.10)

## 2.4.10 Input Pointers

It is signals that can be routed to the inputs of the logic functions, timers and relay 2.

Zero ('0')	MinLoad_af	SinglePhase_tf	StartsPerHr_tf	LogicFunc_3
One ('1')	OverVolt_af	EarthFault_tf	Timer_A	! LogicFunc_3
InService	UnderVolt_af	EarthLeak_tf	! Timer_A	Restart
VoltPresentF	VoltSym_af	MinLoad_tf	Timer_B	FrozenContact
OverCrnt_af	HiFreq_af	OverVolt_tf	! Timer_B	
ShortCirc_af	LoFreq_af	UnderVolt_tf	RTClock	
RunStall_af	IsoLockOut_af	VoltSym_tf	! RTClock	
I_Unbal_af	OverCrnt_tf	HiFreq_tf	LogicFunc_1	
SinglePhase_af	ShortCirc_tf	LoFreq_tf	! LogicFunc_1	
EarthFault_af	RunStall_tf	IsoLockOut_tf	LogicFunc_2	
EarthLeak_af	I_Unbal_tf	PhaseRot_tf	! LogicFunc_2	

### 3. DEFINITIONS AND TERMINOLOGY

EEPROM	Electrical Erasable Programmable Read Only Memory (non volatile)
Flash memory	Similar to EEPROM (only block write - non volatile)
Galvanic isolation	It is the principle of isolating functional sections of electrical system so that charge-carrying particles cannot move from one section to another, i.e. there is no electrical current flowing directly from one section to the next. Energy and/or information can still be exchanged between the sections by other means, however, such as by capacitance, inductance, electromagnetic waves, optical, acoustic, or mechanical means.
In service	When the current rise above 10% of full load current it is assumed that the motor is running.
Intrinsic safe	It is a protection technique for safe operation of electronic equipment in explosive atmospheres. The concept was developed for safe operation of process control instrumentation in hazardous areas. The theory behind intrinsic safety is to ensure that the available electrical and thermal energy in the system is always low enough that ignition of the hazardous atmosphere cannot occur.
IrDA	Infrared serial data transmission link.
LED	Light emitting diode (It is used as visual indicators)
RDU	Remote Display Unit – It is a tool to monitor actual values, fault and event records. It is also used to adjust the relay settings. In retrospect, it is a more robust alternative, although not as comprehensive, for a laptop computer with relay front-end software.
MMI	Man Machine Interface – It is a tool to monitor actual values, fault and event records. It is also used to adjust the relay settings. In retrospect, it is a more robust alternative, although not as comprehensive, for a laptop computer with relay front-end software. MMI also refers to the KD-MMI-420-EP in this documentation.
Motor protection relay	It is an intelligent (computerized) unit monitoring an electric motor's current and voltage supply. In case of overloading, phase lost etc. the power supply of the motor will be interrupted by the protection relay to prevent damage to the motor.
Slot	Memory space allocated to keep settings data for relay configuring purposes.
Dongle key	A custom NewElec key that is used to lock or unlock setting memory slots in the RDU and settings in the relay.

## 4. FUNCTIONAL DESCRIPTION

The KD-RDU-420 can be broken down into the following function blocks:

- Micro-Controller
- Keyboard
- IrDA Serial Port
- RS232 Serial Port
- Dongle Port
- Liquid Crystal Display (LCD)

**Micro-Controller** – Is the core of the system. The micro-controller ensures that the operation of the KD-RDU-420 gets executed. The micro-controller also saves settings to EEPROM so that settings can be retrieved after a power loss.

**Keyboard** – Consist of six keys. The keys allow the operator to give commands to the micro-controller. Four keys are used for scrolling through the menus. The ‘ENTER’ key is used to select or confirm a command. The ‘MENU or RESET’ key is used to cancel a command or to reset the relay from a trip condition.

**IrDA Serial Port** – Is a serial wireless communication interface between the RDU and the MMI or PC to IrDA. This will allow the operator to connect to the relay via the RDU without opening the door of the MCC cubical/bucket.

**RS232 Serial Port** – Is a serial communication interface between the relay and RDU. This will allow the operator to view faults, events and setting or change settings, while the door of the MCC cubical/bucket remains closed.

**Dongle Port** – A dongle key gets inserted into the dongle port. Without the dongle key the operator will not be able to change settings on the RDU memory slots or relay. But the operator will still be allowed to view faults, events and settings stored on the relay and RDU. When the dongle key is inserted into the dongle port then any operator can change settings on the RDU memory slots or relay.

**Liquid Crystal Display** – Will allow the micro-controller to communicate with the operator, so that the operator in return can instruct the micro-controller correctly via the keyboard.

## 5. OPERATING INSTRUCTIONS

### 5.1 Getting Started

#### 5.1.1 Installing KD-RDU-420

Following steps must be taken to install the KD-RDU-420:

- Cut a rectangular hole 132.50 mm in length by 72.00 mm in height into the MCC cubical/bucket door.
- Remove the braked from the KD-RDU-420.
- Push the KD-RDU-420 through the hole cut into the MCC cubical/bucket door.
- Screw braked back onto KD-RDU-420.
- Connect the correct voltage to KD-RDU-420.
- Insert CAB0101 into the 'Comms Port' of the KD-RDU-420 and the relay.
- Insert dongle key into 'Dongle Port' if no security is required.

### 5.2 Navigating Through The Menus

Navigating though the menus is done by using the direction buttons, enter key and reset key:

- UP button - It will scroll up in a menu or when in edit mode increment the parameter value at the position of the cursor.
- DOWN button – It will scroll down in a menu or when in edit mode decrement a parameter value at the position of the cursor.
- LEFT button - It will allow in edit mode to go left when editing a parameter value.
- RIGHT button – It will allow in edit mode to go right when editing a parameter value.
- ENTER button - It will allow going into a sub menu or confirm a change that was done to a parameter value while in edit mode.
- RESET/MENU button - It will allow one level backwards in the menu structure or reset the value that was changed while in edit mode.

### 5.3 Monitoring Actual Data

When auto scrolling is enabled in the RDU Settings menu, the display will automatically return after five minutes of no keyboard interaction to the Actual menu.

### 5.4 Change or Viewing Settings

All features below can be found under the settings menu of the RDU. Range checking of settings is done during editing.

The operator cannot change settings in the RDU memory slots or the relay, if no dongle key is connected in the dongle port.

#### **5.4.1 Change in RDU memory slots**

After selecting 'RDU memory', the RDU will prompt the operator to select a memory slot (1 to 4). After the selection has been made, the RDU will display all the settings of the selected memory slot. When finding the setting to be altered, the enter-key has to be pressed in order to alter the setting. A flashing cursor indicates that the setting is ready to be altered. The enter-key must be pressed to confirm the change, while the reset key will restore the previous value.

#### **5.4.2 Copy RDU memory slot to RDU memory slot**

RDU memory slot 5 is by default the memory slot where the relay settings will be uploaded to when the RDU connects with the relay. When selecting copying memory slot the RDU will prompt the operator to select from which memory slot (1 to 5) the data must be copied from. After the operator selects a memory slot, the RDU will then prompt the operator to select a destination memory slot (1 to 4). After selecting a memory slot the RDU will prompt the operator for confirmation to overwrite destination memory slot.

#### **5.4.3 Upload relay settings to RDU memory slot**

When the operator selects to upload relay settings the RDU will prompt the operator to select the destination memory slot (1 to 4). The RDU will then prompt the operator to confirm the overwriting of the designated memory slot. The RDU will then proceed to upload the relay settings.

#### **5.4.4 Download MMI memory slot to relay**

When the operator selects to download RDU setting to the relay. The RDU will prompt the operator to select the memory slot (1 to 4) to be downloaded. The RDU will then prompt the operator to confirm the overwriting of the settings in the relay. The RDU will then proceed with download of the relay settings.

### **5.5 Retrieve and Uploading Event / Fault Records**

To retrieve event records the operator has to go to events menu. When arriving at the events menu the operator has to select the amount of events required [10 – 2000]. When the enter key is pressed the RDU will begin to upload events to RDU memory.

Fault records are retrieved and uploaded in a similar way except for the fact that all the faults

[60] will be retrieved and uploaded on request.

## 5.6 Trouble Shooting (Frequently Asked Questions)

Why does the “COMMS” Green LED not come on ?

- Make sure that the cable between the relay and KD-RDU-420 is CAB0101 and properly connected.

Why is the screen not reading clearly ?

- Adjust the brightness in the RDU SETTINGS menu.

Why does it take a such long time to upload the events ?

- Due to the amount of events and the board rate of 19200 bits per second.
- Future devices will be looked at to improve the rate of data exchange.

## 6. DIAGRAMS

### 6.1 Physical Layout of the RDU

(Order number: FPR0218)

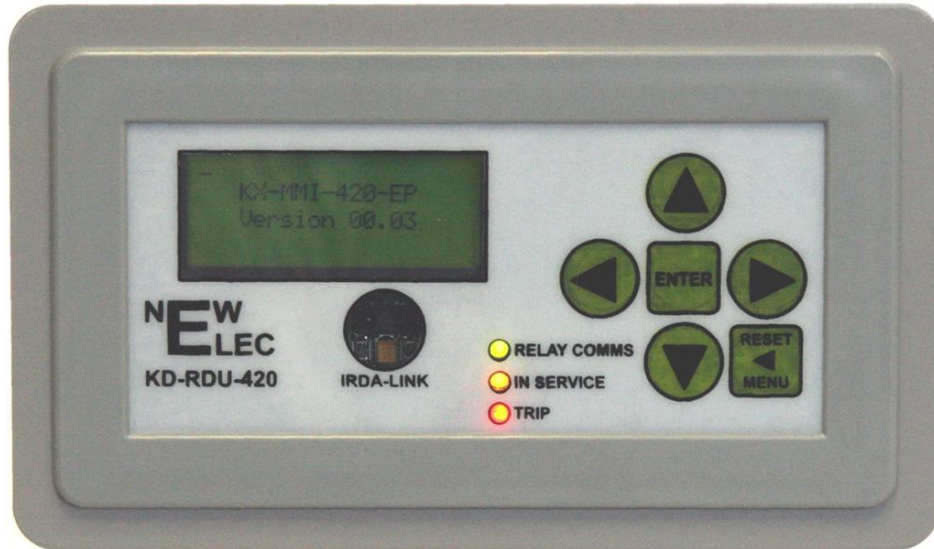

### 6.2 Layout Of RDU Front Panel

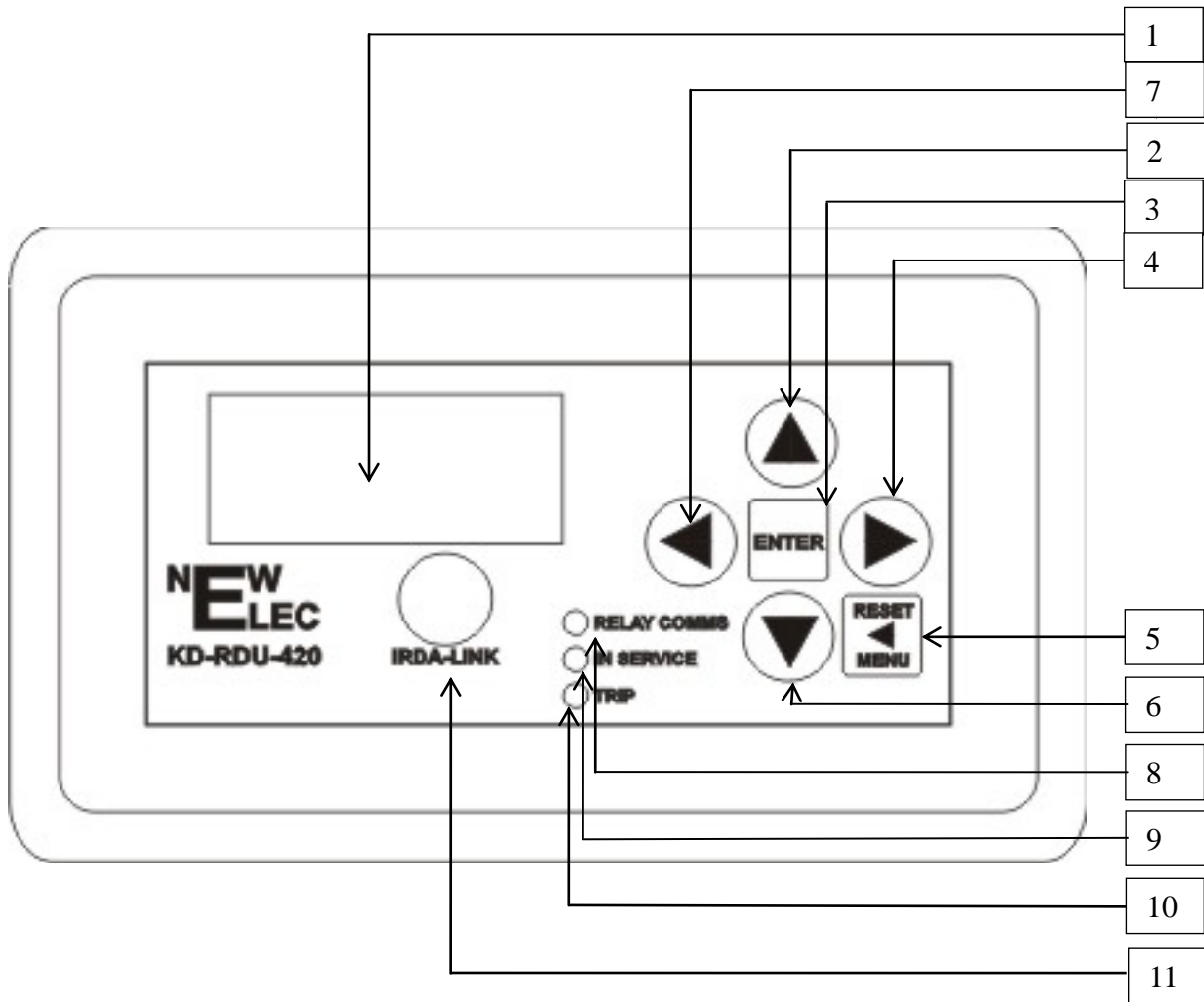

1	Liquid display unit (4 x 20)	7	Left key
2	Up key	8	Communication indication
3	Enter key	9	In service (motor run) indication
4	Right key	10	Trip indication
5	Reset / Menu key	11	Infra red link for MMI or PC to IrDA.
6	Down key		

### 6.3 Layout Of RDU Back Panel

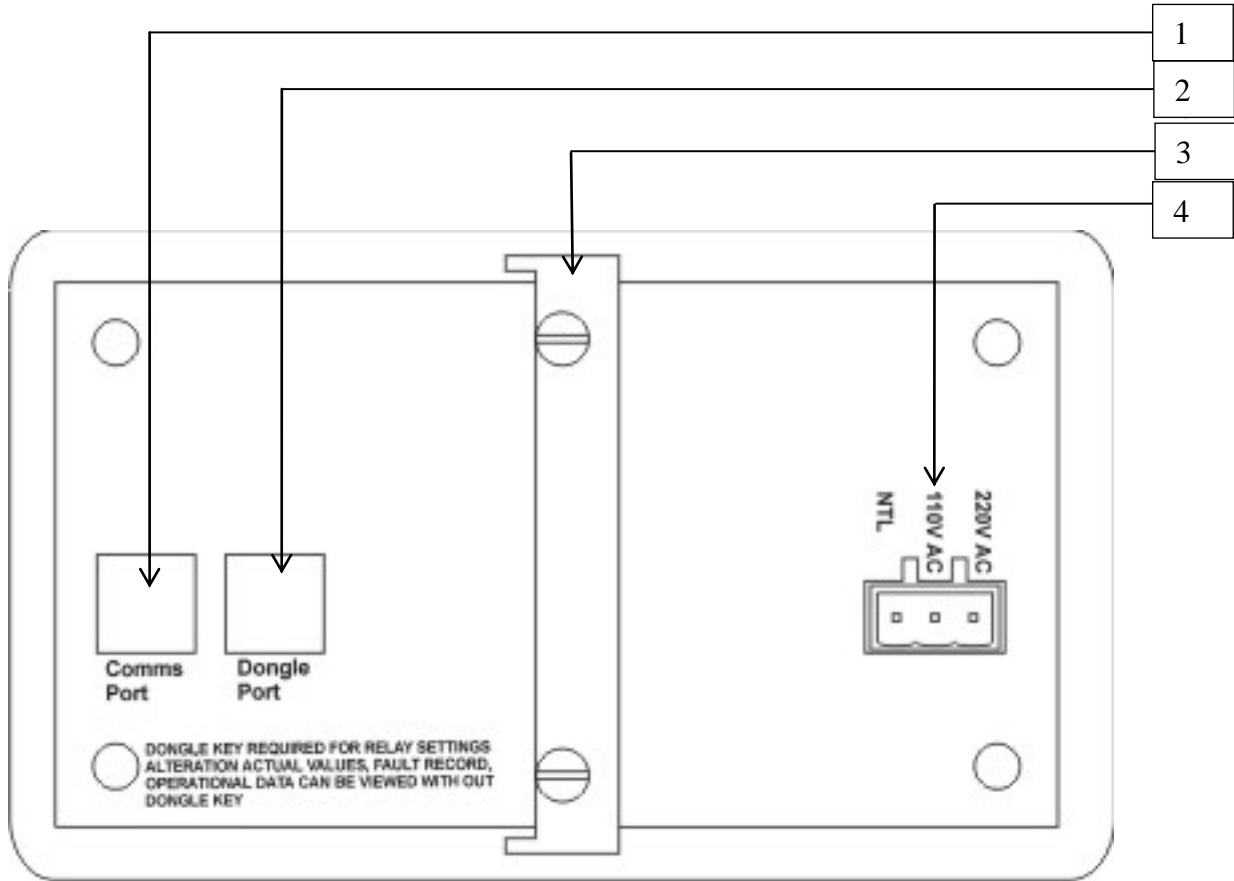

1	Communication to relay	3	Braked
2	Dongle key port	4	Power supply port

## 6.4 Block Diagram of RDU Display Unit

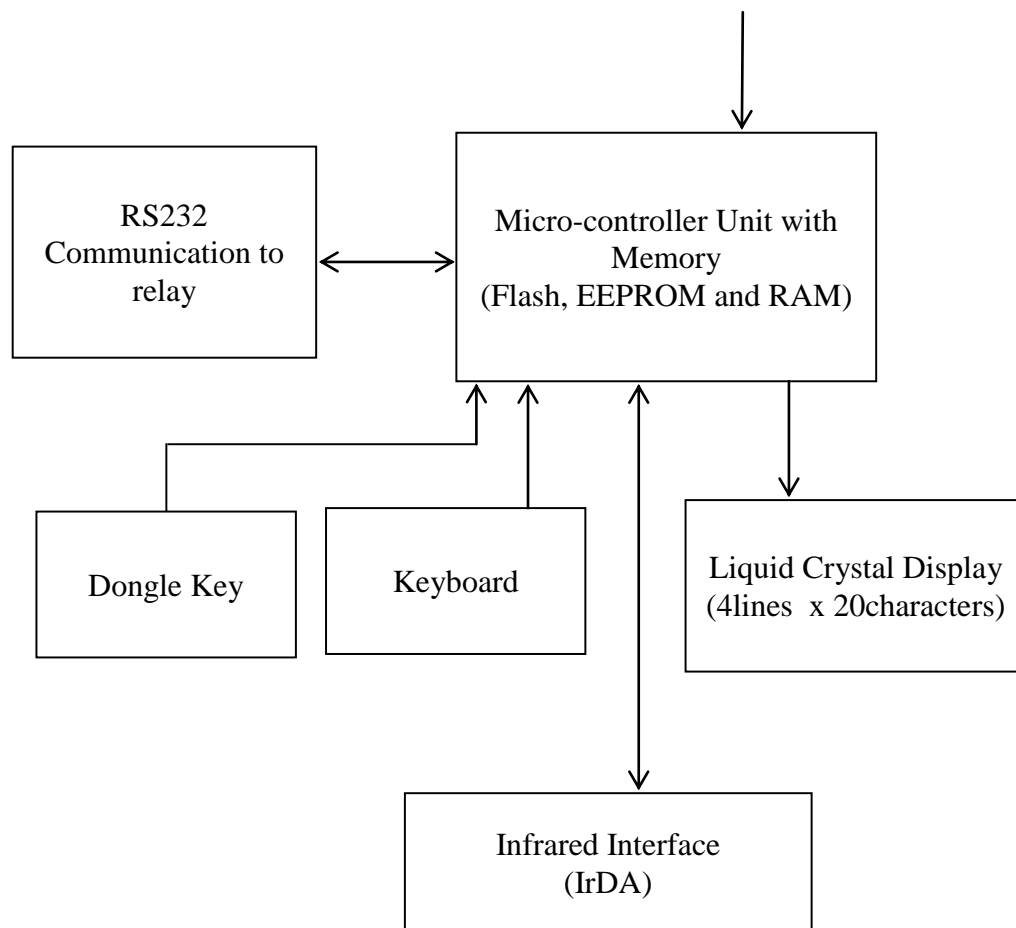

## 6.5 Menu Layout

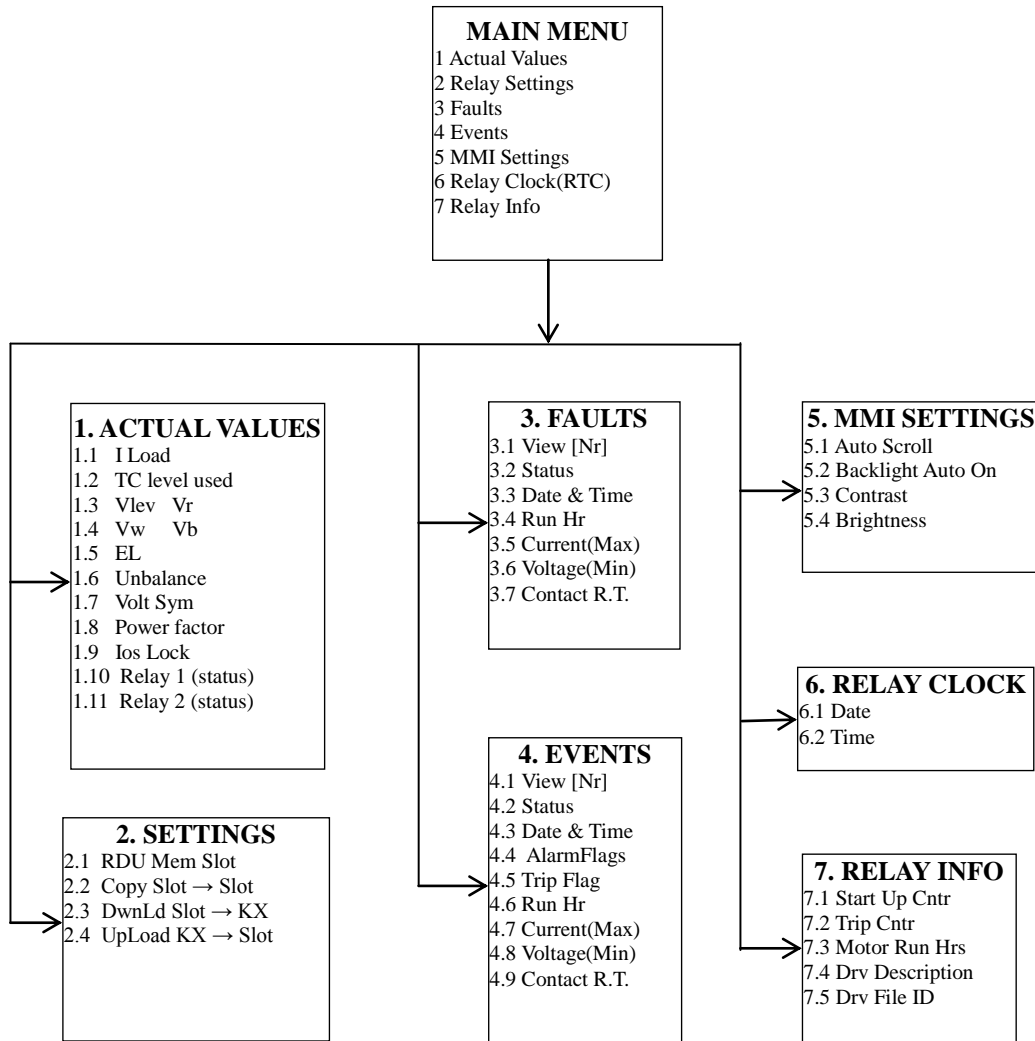

### 6.6 Mechanical Installation Drawing

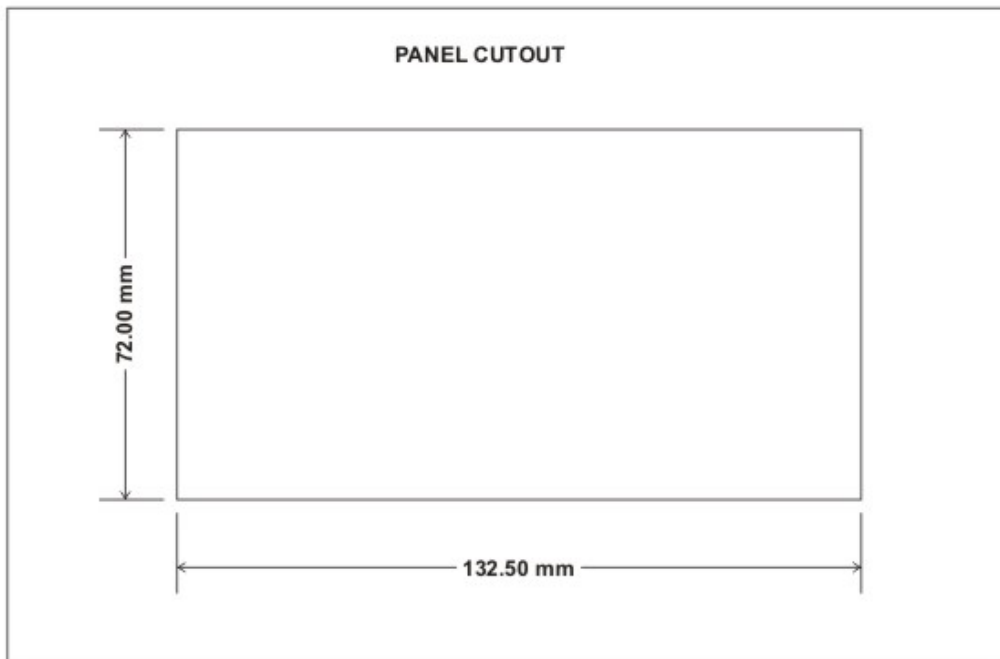
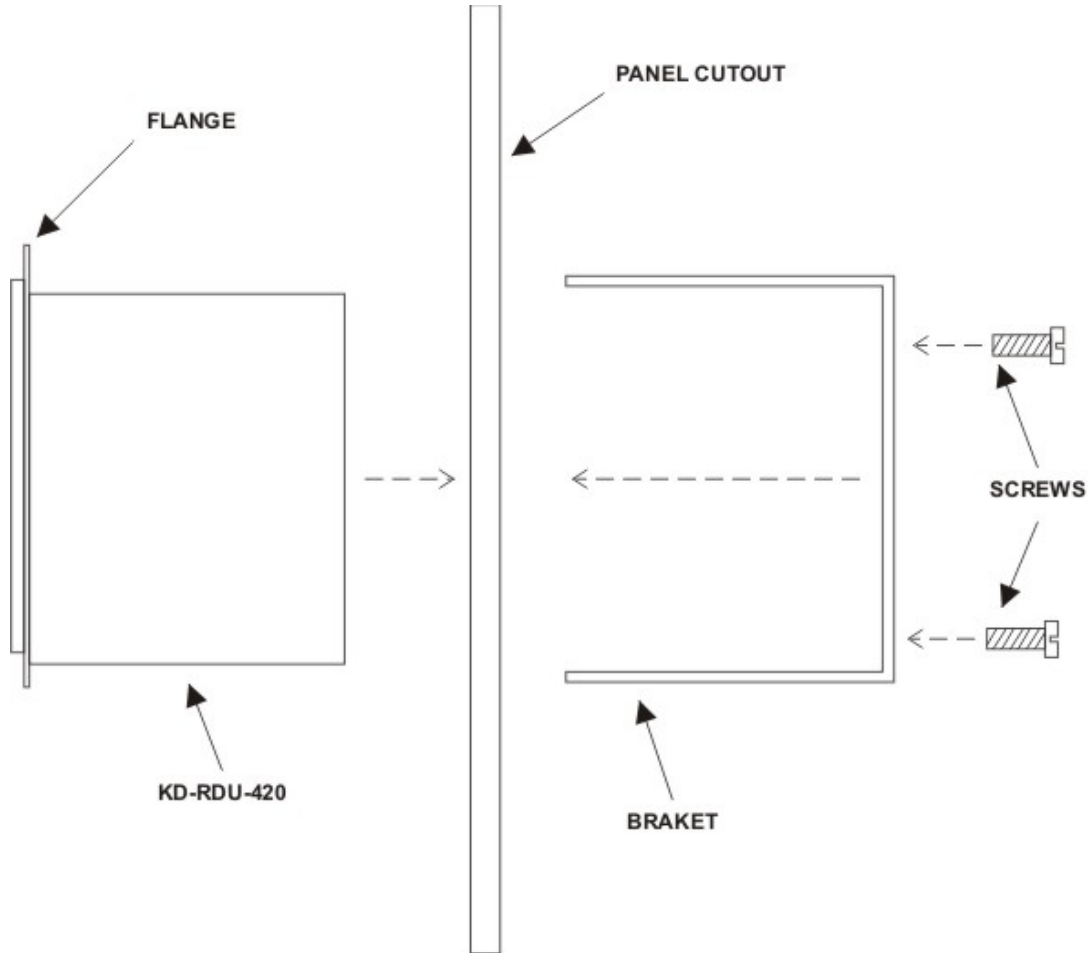

### 6.7 Wiring Diagram

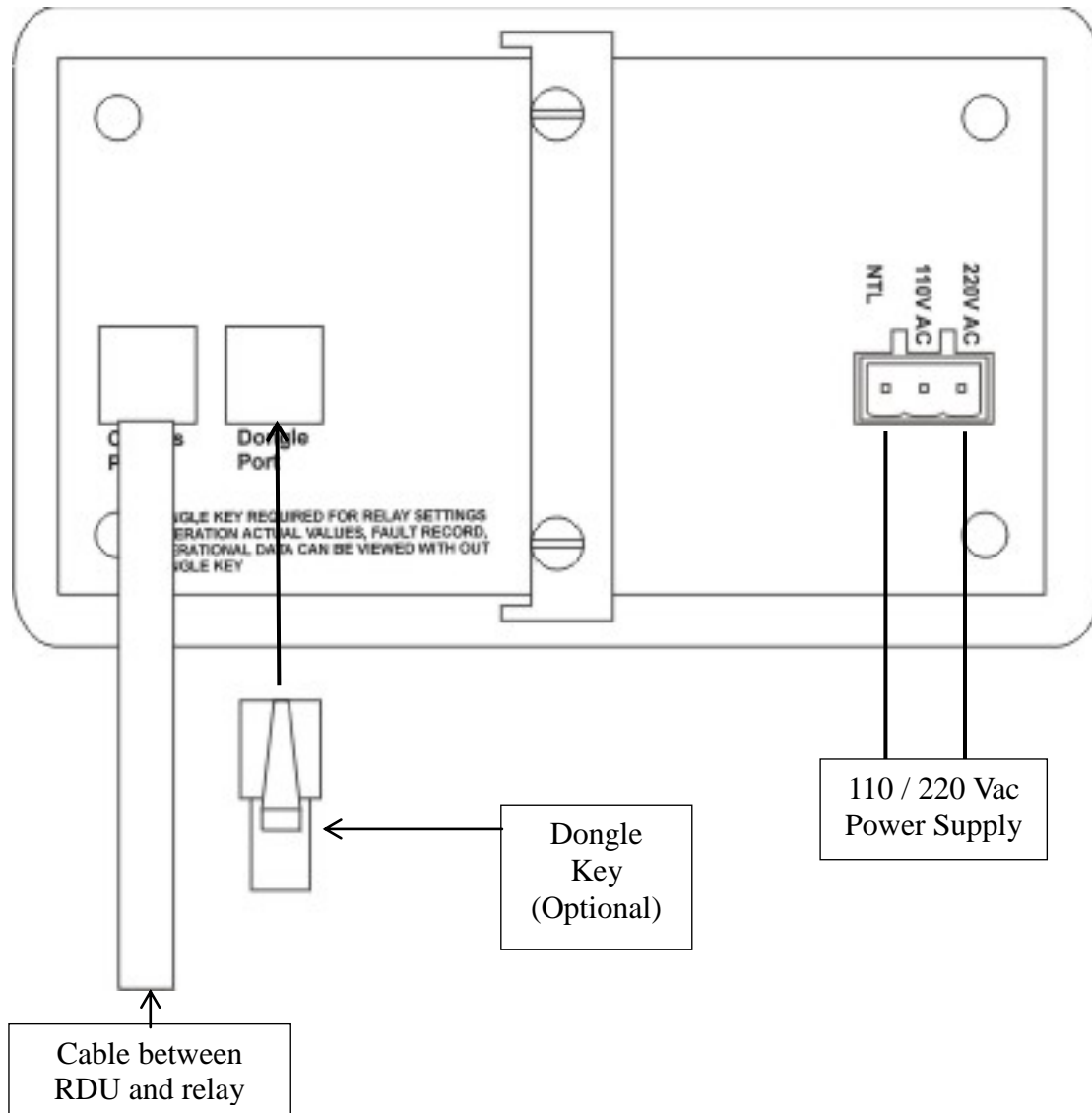

### 6.8 Mechanical Drawing

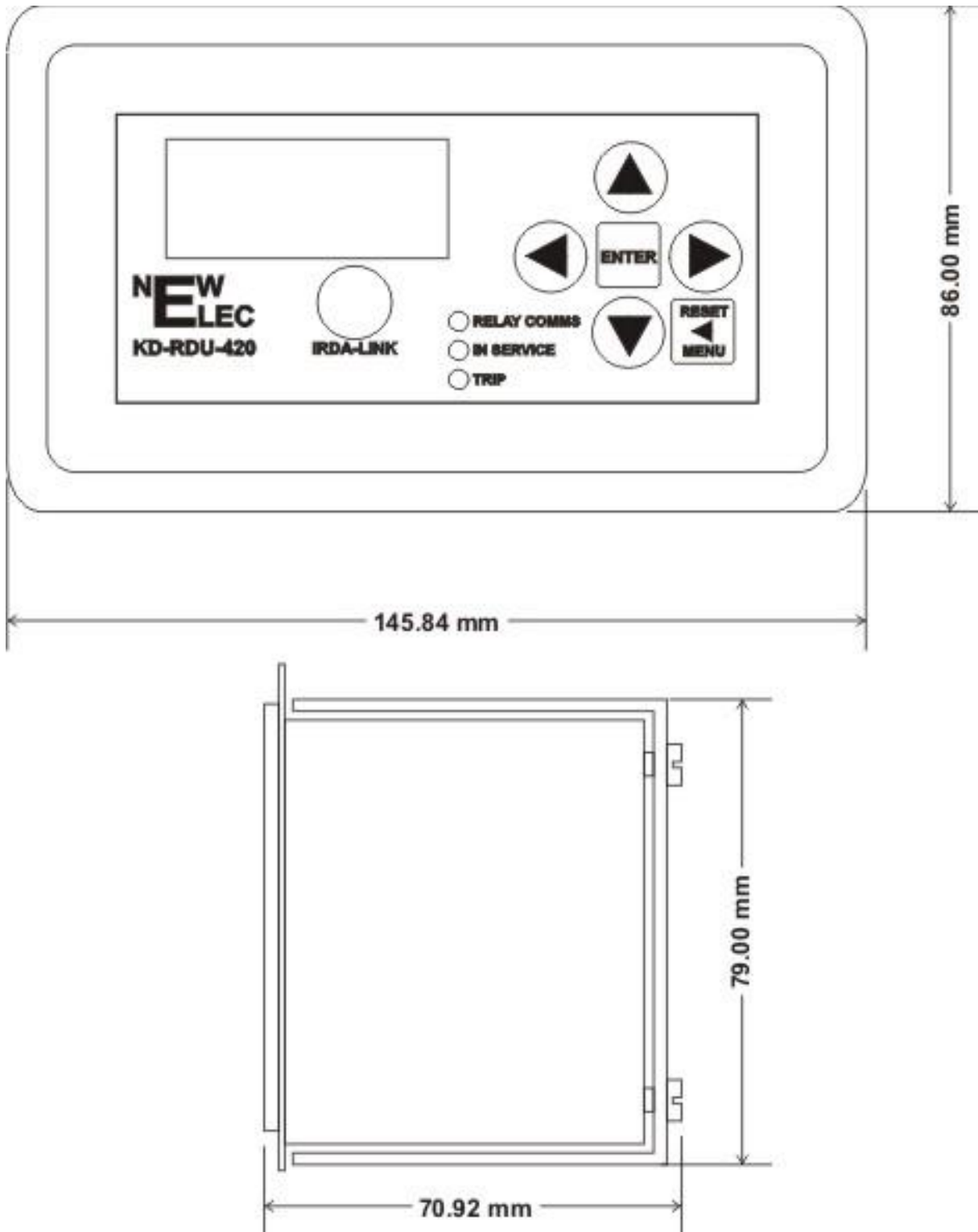

## 7. ACCESSORIES

When ordering FPR0218 all accessories will be included. But can be ordered separately.

### 7.1 RDU To Relay Communication Cable

Order information: NewElec RDU to relay communication cable (CAB0101)

### 7.2 NewElec RDU Dongle Key

Order information: NewElec RDU dongle key (CAB0027)

----ooOoo----